



Adjustable for complex shapes



Cladding screens



Advertising opportunities



## Screen Saver

Self-climbing perimeter protection screen

- Easy to use and re-use:  
reduces lifting by half
- Platforms at every floor level
- Fully adjustable horizontally  
and vertically
- Non-loadbearing balconies  
easily accommodated
- Fits around shaped buildings

# Screen Saver

**Screen Saver is a full height safety screen system, which protects four floors whilst requiring only two levels of anchorage.**

**Screens therefore only need to be lifted after completing two slab pours.**

**This means substantial savings in crane time and a consequential reduction of the overall construction schedule.**

**Screen Saver is based on standard 2.8m wide modules with sliding panels on either side, opening out to 4.8m. This provides dimensional flexibility when catering for different building shapes and reduces the number of screen units required. Completed units are lifted directly from the delivery vehicle on to the building with minimal site assembly required.**

## **Mounting**

Screen Saver can be mounted on the building, free standing, at ground level to give edge protection from day one, avoiding interruption of the upper floor construction cycle.

The screen is fully platformed at all levels, and forms complete closure between slab edge and walkway platform thus eliminating falling debris along this busy interface. Platforms can be adjusted, both vertically and horizontally, to cater for any variation in storey height and column grid without having to remove the screen from the building.

## **Facings**

Screen Saver is faced with durable lightweight aluminium perforated sheets, replacing the open steel mesh of the original Ischebeck Titan screen system. This provides increased protection, ensuring even the smallest particles of debris are contained within the site.

Consequential savings in weight promote quicker and more manageable movement of the system.





Pre-assembled units ready for delivery

## Key features

- 11.9m unit cantilevers up 2½ floors, up to 3.3m floor to floor height
- 14.4m unit cantilevers up 2½ floors, up to 4.2m floor to floor height
- Fully platformed on all levels, providing complete closure
- Only two levels of anchors
- Can be set up at ground floor level

## Benefits

- Provides four platforms for easy secure closing of all gaps
- Lifting every second pour reduces lifting time by 50%
- Fully adjustable both horizontally and vertically
- Lightweight aluminium sheets reduce wind load and material weight whilst providing ventilation and light penetration
- Shaped buildings easily accommodated
- Cladding screen now available for fixings of all facade elements
- Climb up/climb down demolition screens also available

## Design Services

Ischebeck Titan will fully design your screens showing any adjustments up the building.

The screen movements on complex building shapes will be fully sequenced to show any adjustments.

We provide ply layouts, which enables the contractor to cut on-site prior to delivery of the Screen Saver and speeds up the build time.

## Operations

Screen Saver units are pre-assembled for rapid erection on site. Timber and plywood can also be installed prior to delivery, in our purpose built facility, to improve installation time.

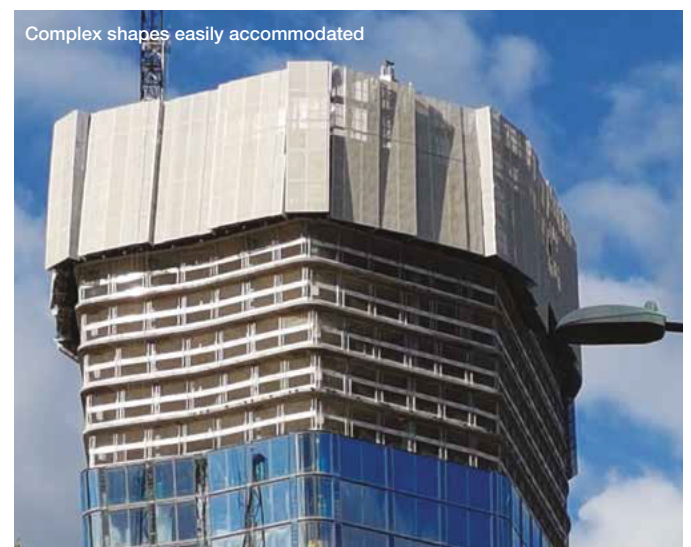

Complex shapes easily accommodated



# Standard units: main features

## Units

Standard heights: 11.9m

- Covers 2½ floors up to 3.3m floor heights

14.4m unit: (11.9m standard unit height + 2.5m extension)

- Covers 2½ floors up to 4.2m floor heights

## Adjustable sliding screen panels

- Sliding panels are captivated on the inside
- Movement from the platforms on the inside of screens
- Each panel weighs 26kg
- Aluminium extrusion – no rust and easy to slide
- Minimal gaps between panel



## Adjustable frame positions

- Allows possibility of accommodating different floor to floor heights
- Moved without disassembly
- Can be moved in-situ

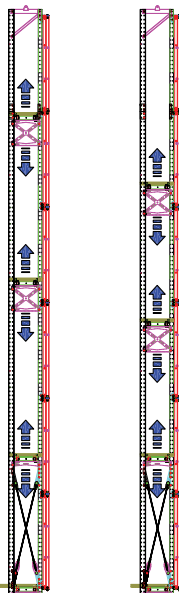

Front elevation



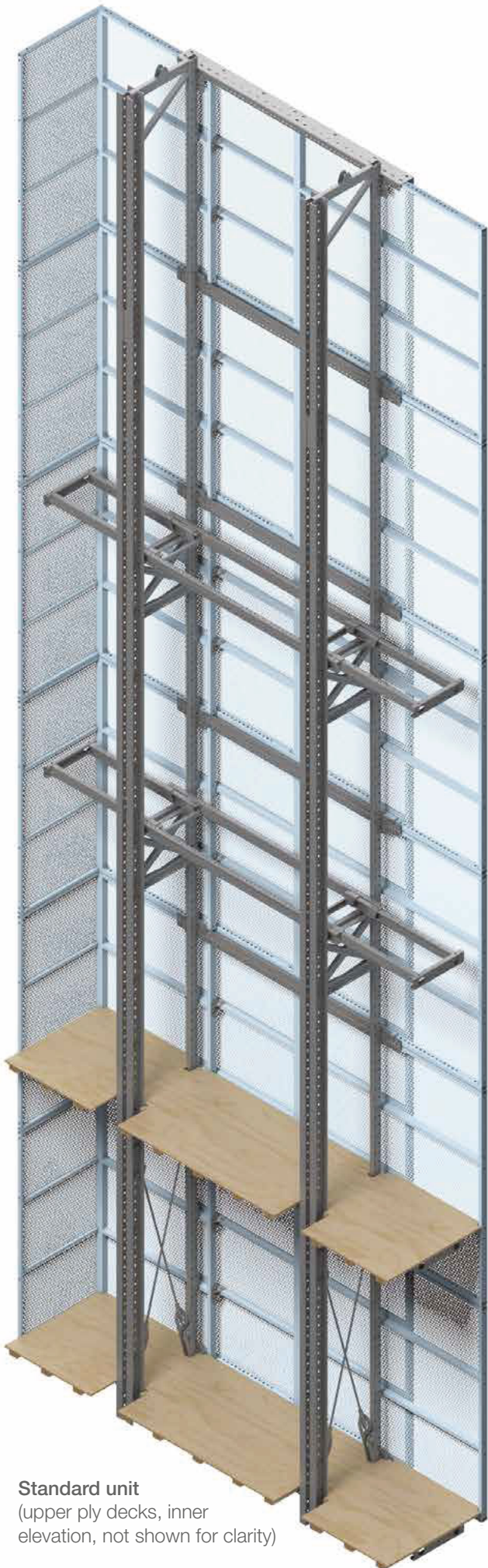

**Standard unit**  
 (upper ply decks, inner elevation, not shown for clarity)

## Panels

- Aluminium perforated sheet with 40% porosity, i.e. 40% of wind will pass through
- Allows combined wind relief/working protection/sunlight and ventilation to lower levels
- Sheet is suitable for accidental impact loads
- Holes are 6mm diameter with 9mm staggered pitch



## Adjustable platforms and panels

- Units stay assembled, and are adjusted for site specific requirements
- 2.8m maximum width for transport
- Opens out to 4.8m maximum width (option to increase to 5.8m depending on design criteria and site logistics)
- Only plywood is job specific
- Store the fully assembled units with minimal adjustment for next use

# Concertina units: allow screen adjustment whilst on the building

## Units

**Standard heights:** 11.9m or 14.4m (using a 2.5m extension)

- Covers 2½ floors up to 3.3m floor heights

**14.4m unit:** (11.9m standard unit height + 2.5m extension)

- Covers 2½ floors up to 4.2m floor heights

## Concertina deck

The concertina deck can be adjusted whilst the screen is attached to the building. This adjustment facility has been designed to suit any required change in geometry to the floor footprint.

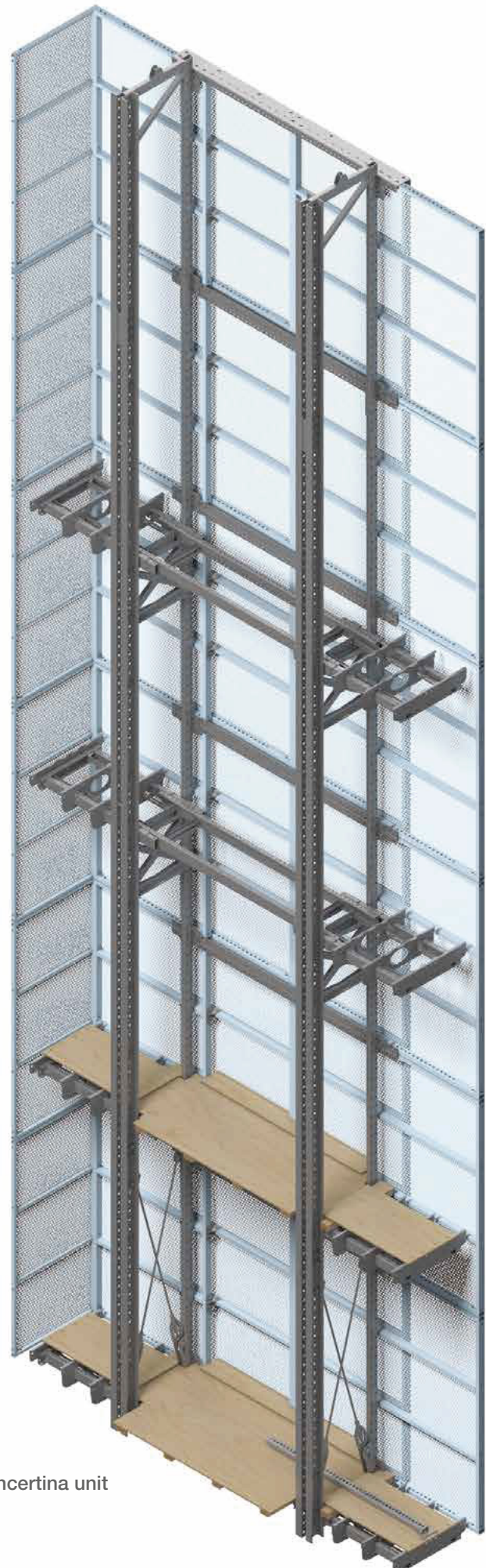

Concertina unit





**Cheeta Cleat and detail**

Allows on-site adjustment of the screen

Weight (kg)	Code
1.67	407202

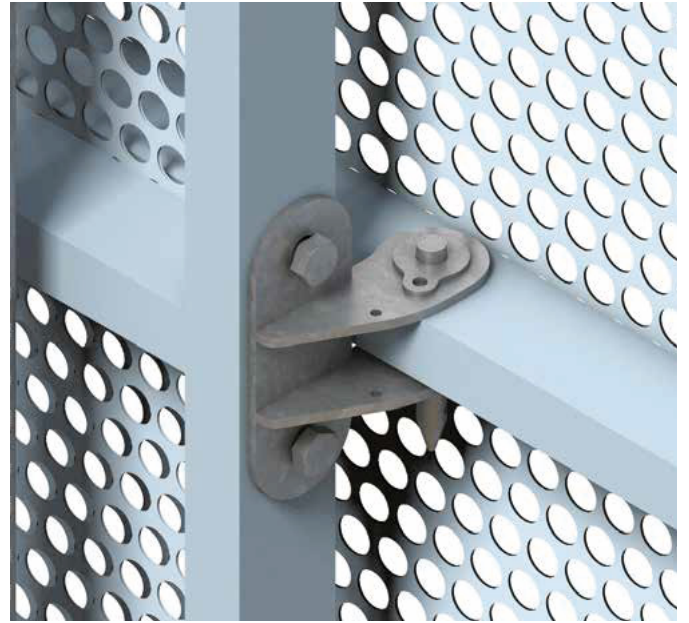

Cheeta cleat locks sliding panel in place



**Concertina deck 1000**

100mm to 1000mm adjustment (longer 1500 units available if required for on site adjustment).

Unit	Weight (kg)	Code
1000	47.7	407510
1500	50.9	407680



**Cantilever detail**

Showing adjustment tool in place ready for screen width adjustment whilst insitu

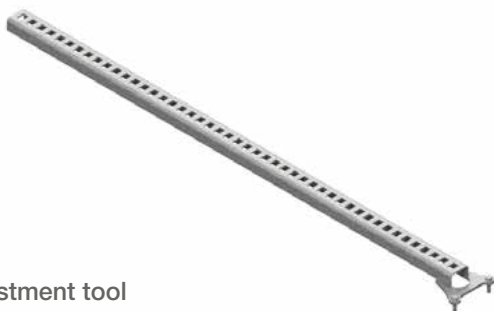

**Adjustment tool**

Weight (kg)	Code
11.3	409450*

\*Tool and spanner



**Spanner**

# Ancillary components

## Needles

- Rotating guides for easier install/release
- Guides can be parked in open position to aid installation
- Latches open and close
- Attached to Titan Universal Soldiers
- Alternatively anchor direct to wall



## Needle anchoring

Ischebeck Titan anchor bracket (with 40mm longitudinal and 15mm lateral adjustment) provides tolerance for setting out of anchors.

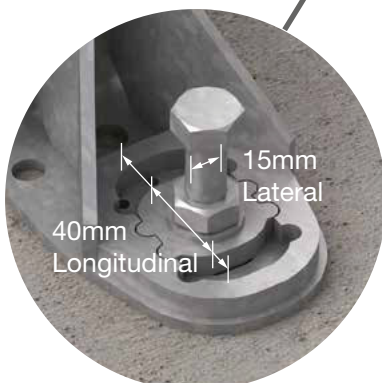
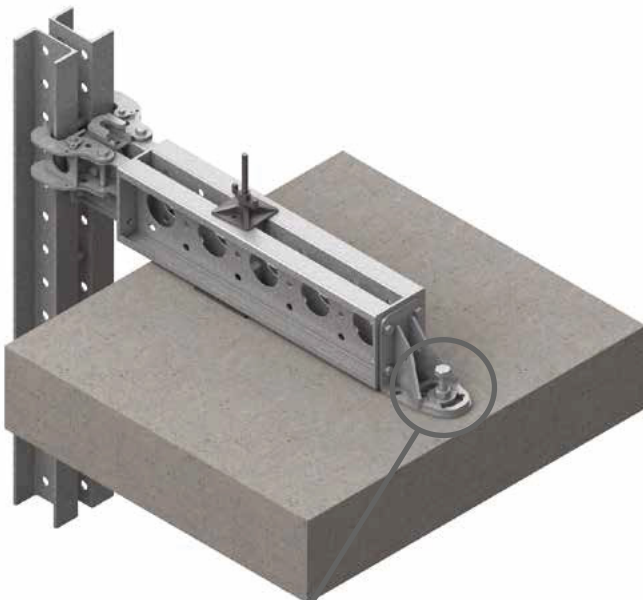

## Joggle Box Beams

Used to raise needles over upstands or neighbouring needles at corners. Can be used to raise over 0 – 225mm.

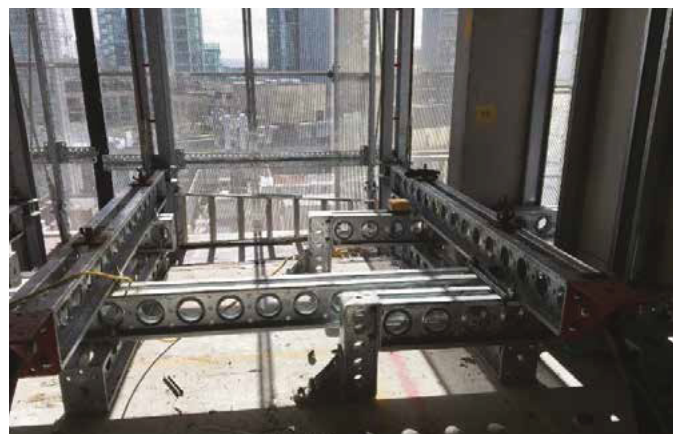



## Centurion Anchor Bracket and Smooth Mover Tool

- Used to slide the needles up to 250mm
- Changes the inclination of the screens without using the crane
- Aids screen adjustment on varying shaped buildings without the need for a crane

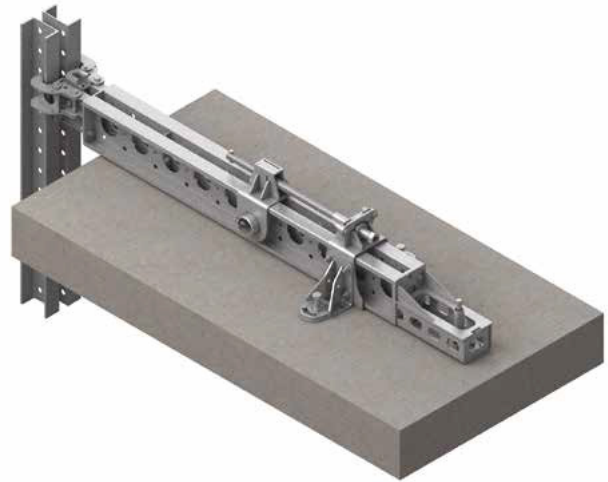

## Gap sealing solutions

Completely seals the building against falling material

### Plastic gap sealers

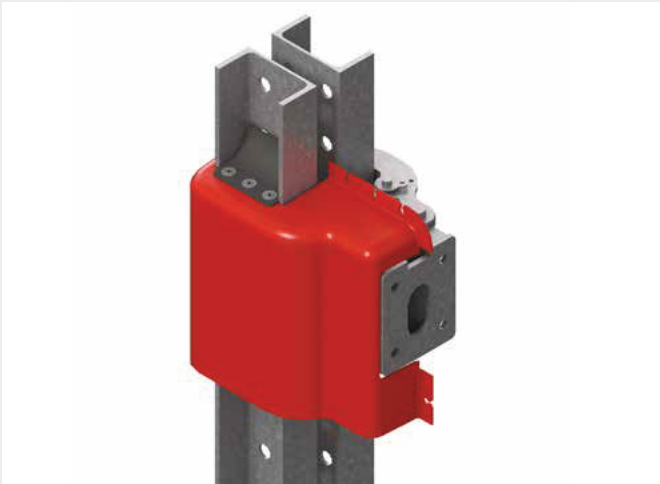

### Screen rubbers

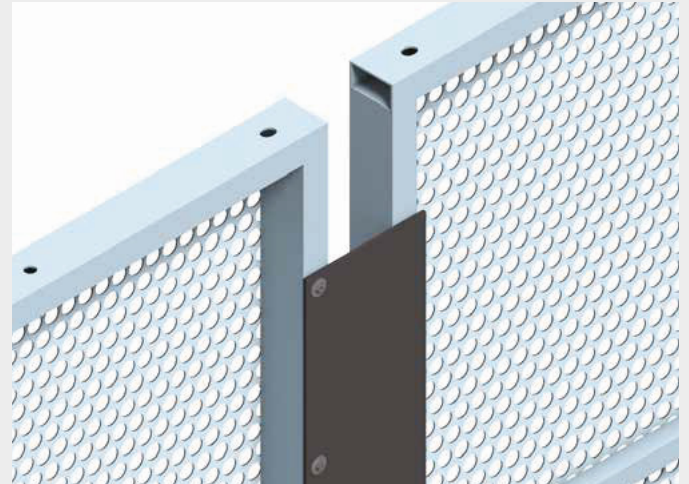

### Pull out decks

Pull out decks can be fixed to the front of the decks to adjust against the building



### Velcro

For corner sealing



# Lifting

## Hydraulic lifting

- Ram Head Assembly
- Hand latching side guides
- Easy handling, offering and fixing to screen soldier

## Rams

- 565mm stroke
- 400mm effective lift per cycle
- 2 minutes per metre lift time
- Easy slot into Needle via doorknob end to the rams

## Hydraulic pump units

- Runs from 110v, 32A
- Easy to manoeuvre
- Geared flow divider for equal ram speeds (independent of imbalanced loads)
- Operated from remote control (or directly)
- Can add splitter unit to allow 4 rams
- Uses eco-friendly, biodegradable oil

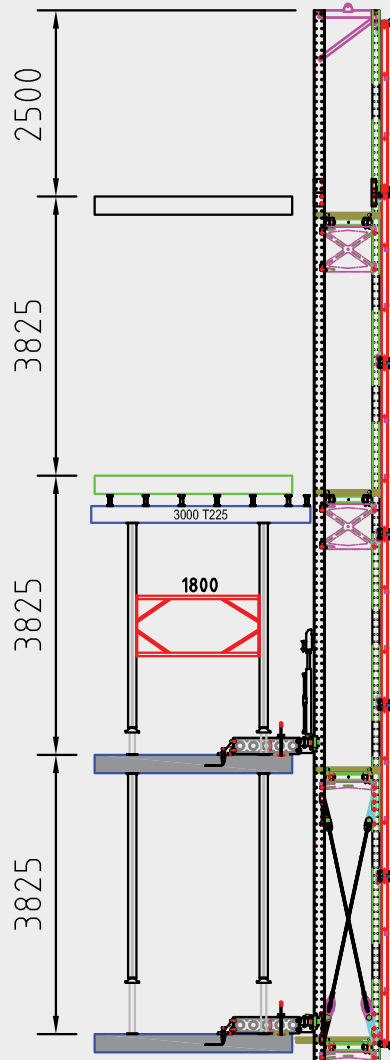

3.825m  
2½ floor cantilever

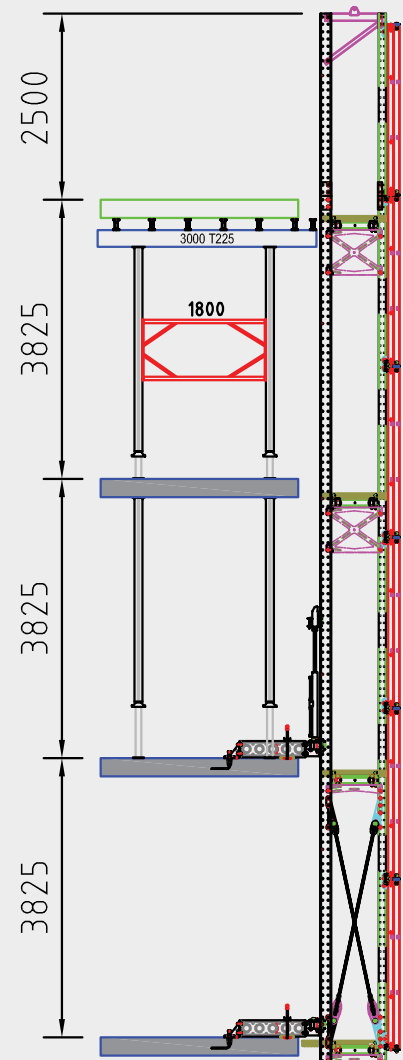

3.825m  
2½ floor cantilever



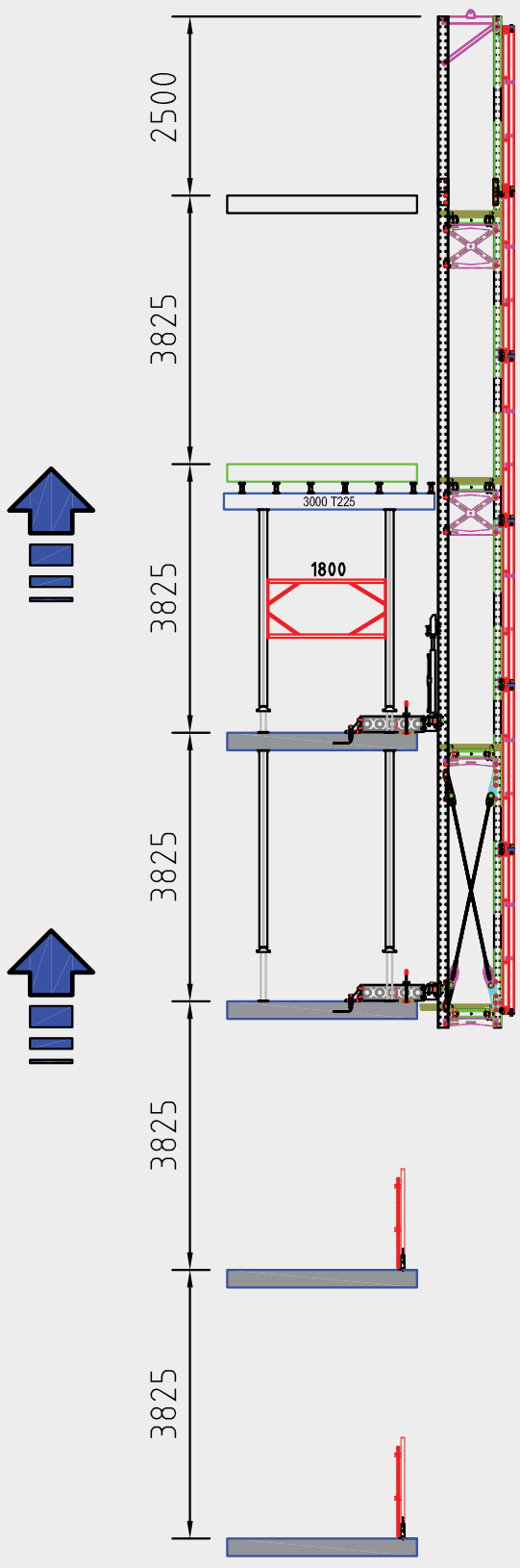

3.825m  
2½ floor cantilever

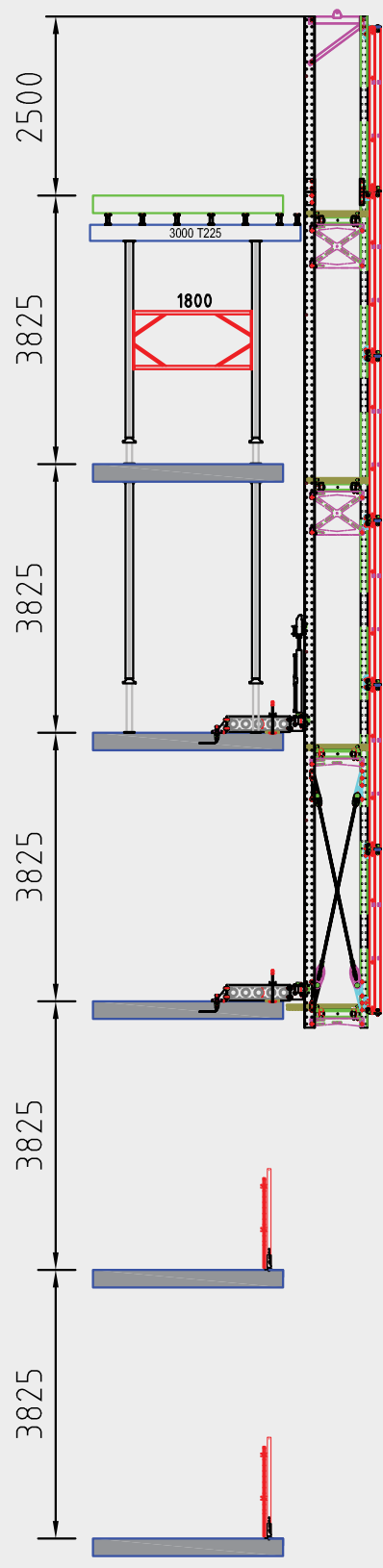

3.825m  
2½ floor cantilever

# Standard Screen Saver Units

Ischebeck Titan has a large hire stock of assembled screens ready to be adapted for your job.

The engineering team can adapt the screens to your specific requirements, accommodate changing footprints, balconies, large cantilevers, changing floor heights etc.

However complicated the structure.... Ischebeck Titan can provide a completely encapsulated and safe screen solution.





# Angel Gardens, Manchester

- 38 storey, luxury residential development, in Angel Street, Manchester.
- 11.9m Screen Saver units required for full perimeter protection. Preassembled to strategic dimensions to allow for varying floor heights as building progressed
- Structure featured a level 8 cantilever slab, extending from 0 to 3m over the full length of the 40m building, within close proximity to the roadside below
- Solution – a screen system which utilised extended cantilever needles to achieve required position away from the structure. The Screen Saver protected the public below and also enabled the forming of the level 8 cantilever slab by providing a structural platform from which to position Titan falsework

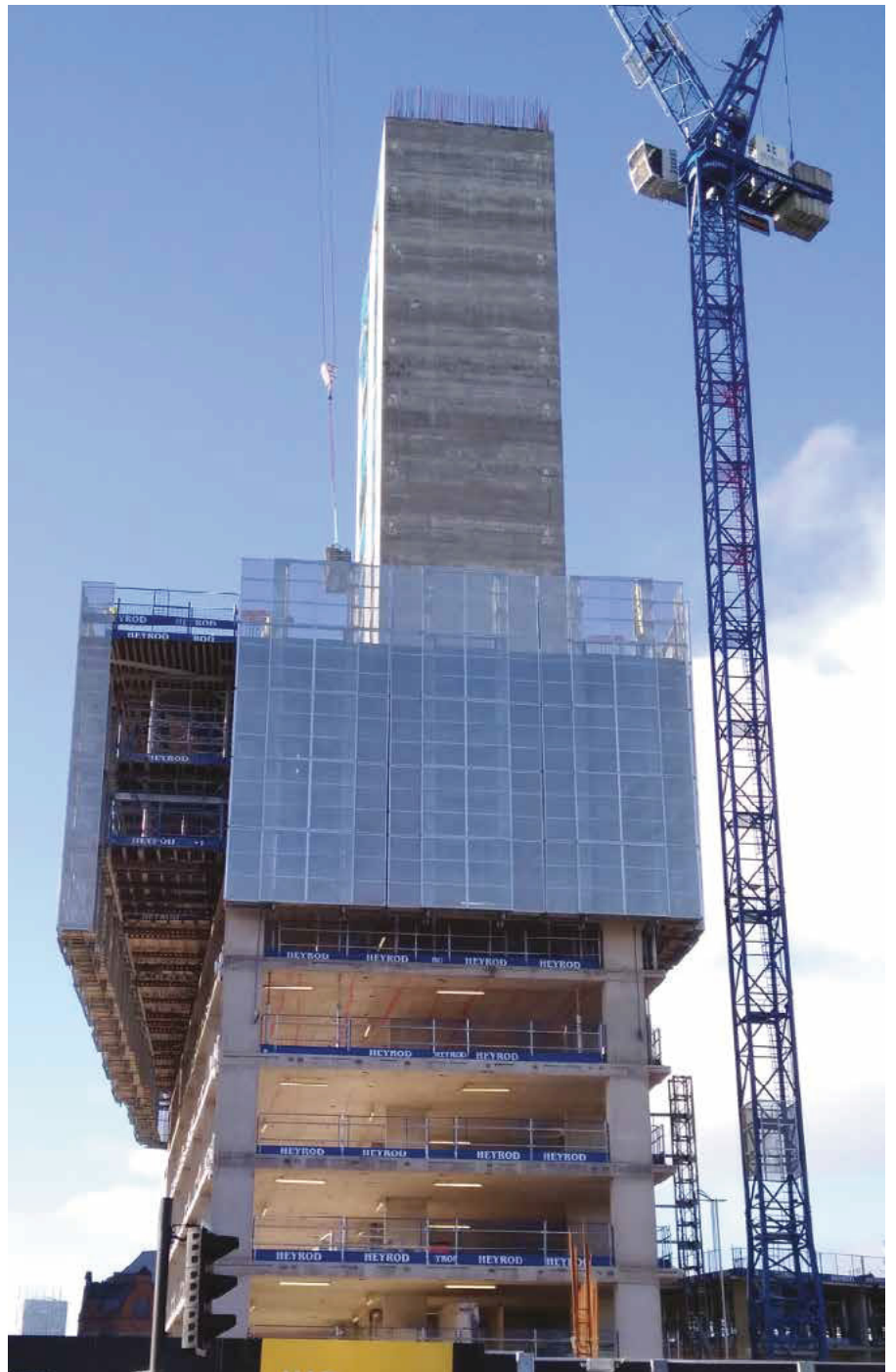

# Formwork hoists

The formwork hoist climbs up the building covering four floors for movement of formwork material between floors without the use of a crane. The hoist is gated with electronic sensors so gates can only open when hoist is local to the floor.

Hoist is fully enclosed within a screen cage for full safety during use.

Note: The hoist is materials only, site personnel **must not** ride within.



Screen Saver Loading Bay [1] and Hoist [2]



Screen Saver Hoist

# Loading bays

Two tonne loading bays for crane movement of formwork between floors.

Loading platforms are safely installed with all connections being made from behind screen protection.



Loading bays



# Staircase units



Stair screens



Screen Saver unit with integral staircase

Used on a standard screen for access between platforms. Staircase units can be built into strategic screens to facilitate quick people movement between floors. Staircase climbs with the screens to give constant access up the construction floors.

# Cladding screens

Cladding screens provide complete protection to the floors being constructed, with the finished building being extruded from behind purpose built cladding screens.

Adaptable for most cladding types.

- Used for 'stick' system facades; elements of the facade are installed piece by piece
- Multiple level access for different operations
- Additional flexibility of the platforms to close gaps
- Pull out drawers to close off the building
- Folding decks for quicker installation/less laydown area
- 200mm wider than a standard screen

## Folding decks

Folding decks have been developed to allow the Cladding Screen to be positioned directly onto the building from the flatbed trailer. While on the trailer, all decks are folded away. On arrival to site, the bottom platform decks are opened and lowered into position.

The Screen can then be lifted onto the slabs and fixed.

Using the bottom platform, the platform above can be moved into position and fixed underneath. The other decks can then be assembled in this manor using the deck below.

Note: Folding decks can also be provided for standard construction screens.



## Folding decks sequence





# Case Study: 27 Commercial Road, London

- 21 storey structure in Aldgate, London
- Located on a busy highway with site space at a premium, screens were delivered pre-assembled, assisting with quick, safe and efficient unloading and minimal make-up on site
- Contractor required to install traditional brick masonry facade, without using an external scaffold. The cladding screens provided external access to the building for installation of windows and brickwork, whilst enabling other works to continue on as many levels as possible. Fully gap sealed, the screens provide a safe working environment and complete protection to the public below
- 19 no. 14.4m high x 4.8m wide screens delivered, providing 5 levels of access

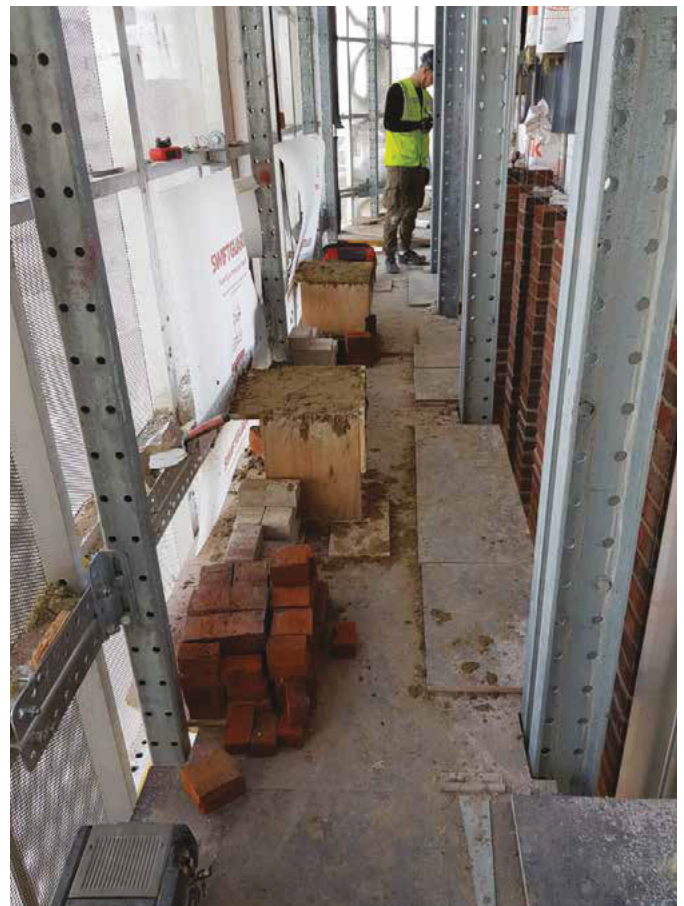



## Freestanding units

### Start safely by enclosing your building against wind and falls from the first levels

- Allows for installation at ground level
- Levelling frame anchored to ground
- Construct 1st floor slab within the screen
- Suitable for use adjacent to railways

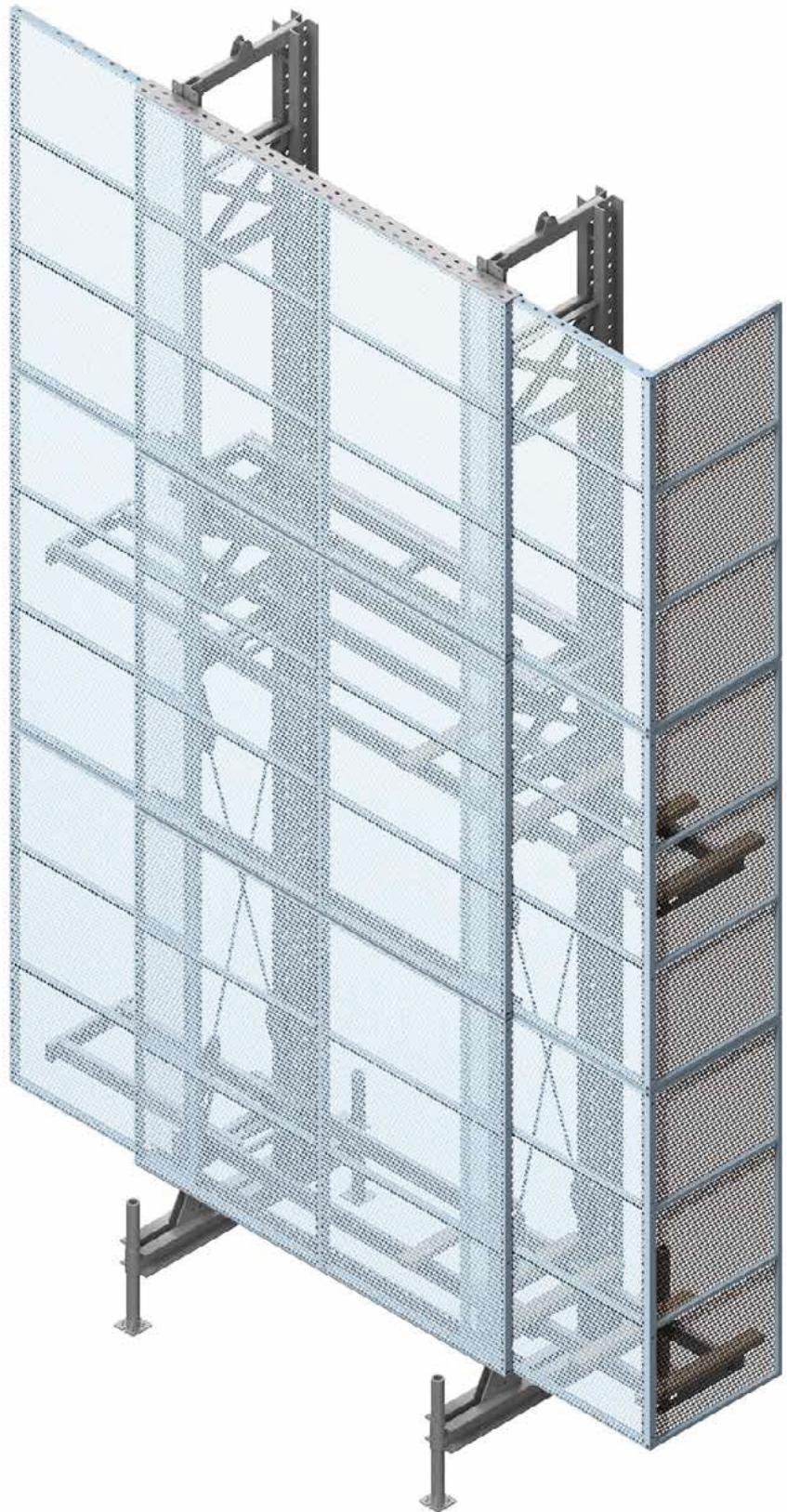





### Screens at ground level

Screens are installed at ground level using a support trestle anchored to the ground to give full screen protection from the first floor level.

No need to adapt formwork at edge.

## FRIEDR. ISCHEBECK GMBH

Founded in Germany over 130 years ago, Ischebeck is one of the world's principal manufacturers of formwork and falsework systems. Renowned internationally for its Titan Support system, the group has a long standing tradition of innovation and engineering excellence. Product quality is a hallmark of the group and the company's manufacturing facilities are amongst the most advanced of their type.

## Ischebeck Titan Limited

Ischebeck Titan is a leading supplier of formwork, falsework, safety systems and ground engineering solutions. The company operates from headquarters centrally located in the heart of the U.K and has a team of product specialists ready to assist you with your concrete construction project.

## Product availability

Substantial stocks of equipment are available ex-stock from the company's strategically located 4-acre distribution site with most items available nationwide on a 48 hour delivery.

Products are available for both hire and outright purchase.

## Technical support

Backed by the resources of one of the most respected names in the industry, Ischebeck Titan offers a comprehensive range of support services.

The company's Technical Services Division can provide a full drawing and structural analysis service using the latest computerised software.

Since our policy is one of continuous improvement we reserve the right to change without prior notice the specifications and methods of construction mentioned in this document. No responsibility whatsoever can be accepted for any errors or omissions in, or misinterpretation of the contents. Products must be used in conformity with safe practices and applicable codes and regulations. Photos and details shown are for general guidance only and may vary according to circumstances. For specific information refer to Ischebeck Titan Limited. Copyright reserved.



**HEAD OFFICE:** John Dean House, Wellington Road, Burton upon Trent, Staffordshire, DE14 2TG

Tel: +44 (0)1283 515677 Email: [sales@ischebeck-titan.co.uk](mailto:sales@ischebeck-titan.co.uk)

**DESIGN OFFICE:** Hollinwood Business Centre, Albert Mills, Albert Street, Hollinwood, Oldham, OL8 3QP

Tel: +44 (0)161 682 4732 Fax: +44 (0)161 684 3603 Email: [technicalsupport@ischebeck-titan.co.uk](mailto:technicalsupport@ischebeck-titan.co.uk)

[www.ischebeck-titan.co.uk](http://www.ischebeck-titan.co.uk)