

Layher Info

Information about products and technology for clients and partners.

Layher® 

More Possibilities. The Scaffolding System.

July 2019

SoloTower

The SoloTower from Layher is a small rolling tower that can be assembled quickly, safely and easily by a single person, up to a working height of 6.15 metres.

Current industrial safety regulations for working at heights are increasingly restricting the use of ladders. These regulations are frequently detrimental to the profitability of businesses. Previously, businesses have had to plan with high-volume work platforms. The result is a major logistic effort, plus an increased personnel requirement of at least two persons.

This additional economic burden is avoided by using the SoloTower.

Thanks to its compact dimensions, the SoloTower can be transported to its place of use in normal commercial vans or trucks. Transport and assembly can be handled by a single person all the way.



TECHNICAL DATA

- ▶ Working height: 6.15 m
- ▶ Area of work platform: 0.75 x 1.13 m
- ▶ Permissible live load: 2 kN/m² (scaffolding group 3)



LOGISTICS

The compact dimensions of all components permit economical and efficient logistics for storage and transport and at the site. A few of the components are used to construct, without any tools, a "transport trolley" in which the other scaffolding parts can be moved quickly and ergonomically to the intended location. This "transport trolley" fits through any normal door.



SAFE ASSEMBLY AND DISMANTLING

With the specified assembly and dismantling sequence of the SoloTower using the 3-T method (Through The Trapdoor ▶ i.e. seated in the access hatch), the user is already in a secure area when moving up to the next platform up, due to the pre-assembled double guardrail, in compliance with the valid regulations for industrial and work safety.



SINGLE-PERSON ASSEMBLY

Lightweight, handy and compact components made of aluminium in combination with the SoloTower assembly hook make it easy to pass individual components from level to level, permitting efficient and economical assembly and dismantling by only one person.

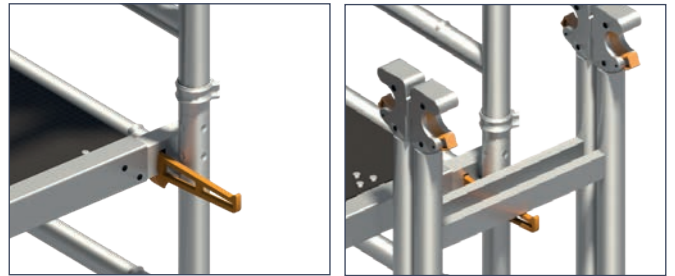

TOOL-FREE ASSEMBLY

Layher's proven connection technology using the snap-on claw permits the accustomed tool-free, fast and easy assembly of the sturdy aluminium components. Layher rolling tower components are synonymous with durability and stability.

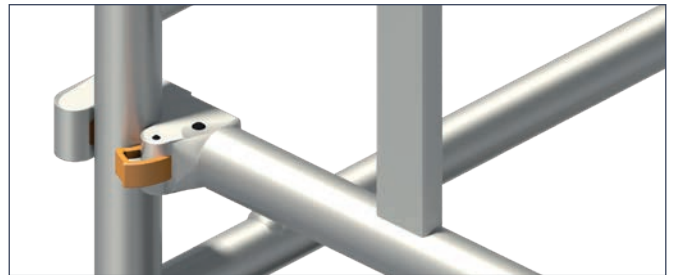

TOE BOARD UNIT

The end and side toe boards made of aluminium are already preassembled to create a toe board unit. The toe boards can be spread out and folded up in next to no time, and fitted to the platform quickly and easily.



THE BENEFITS FOR YOU AT A GLANCE

- ▶ Economical, efficient and ergonomical logistics for storage and transport and at the site, due to compact dimensions of all components.
- ▶ More safety when moving to the next platform up, due to double guardrail preassembled using the 3-T method.
- ▶ Safer assembly and dismantling by only one person, due to passing of the compact components from level to level using the SoloTower assembly hook.
- ▶ Tool-free, quick and easy assembly due to the proven Layher connection technology of snap-on claw.
- ▶ End and side toe boards made of aluminium and preassembled to create a folding toe board ensure rapid fitting to the platform.
- ▶ Design to European standard DIN EN 1004 for mobile work platforms, for maximum quality and safety.

TELESCOPING STABILISERS

Quickly and easily attached stabilisers ensure a firm standing of the SoloTower on uneven ground too.

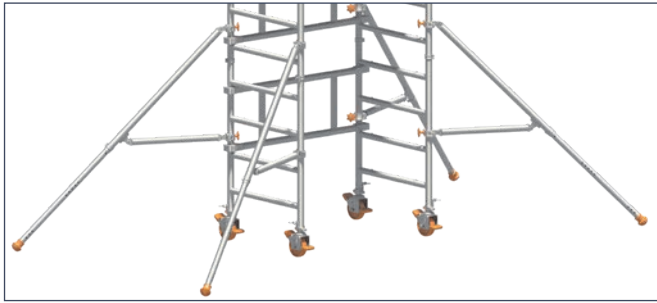

WHEELS

Sturdy wheels for high manoeuvrability and stable stance during work. The steel base plates ensure easy and precise height equalisation while transmitting the loads centrally into the locked wheel. This improves the stability and enables the user to work efficiently.



QUALITY AND SAFETY

The SoloTower has been designed to meet the requirements in the European standard DIN EN 1004 for mobile work platforms, ensuring maximum quality and safety.

ECONOMIC EFFICIENCY

The ladder frames of the SoloTower are, thanks to the Layher construction kit system, also used for the proven Zifa, Uni Standard and Uni Light rolling towers.









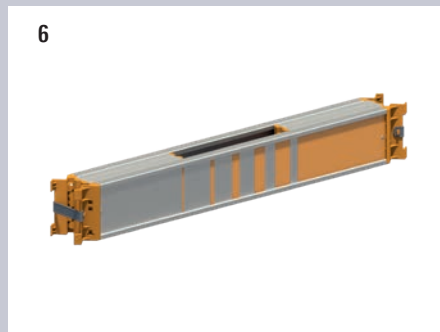
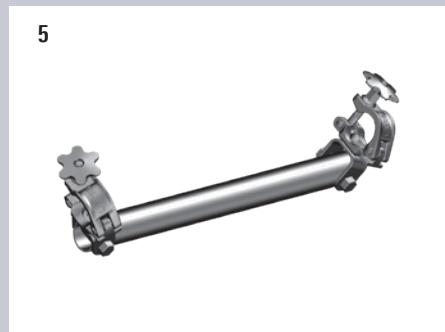
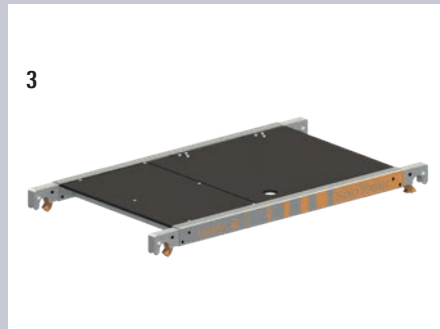
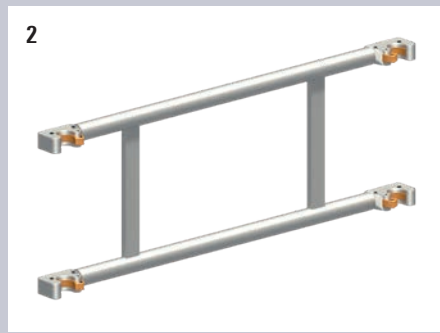

Ladder frame 75/4 | Ref.-No. 1297.004
Also usable for Zifa, Uni Standard and Uni Light

Tower model	1600102	1600103	1600104
Working height [m]	4.15	5.15	6.15
Tower height incl. spigot [m]	3.37	4.37	5.37
Platform height [m]	2.15	3.15	4.15
Weight [kg] (without ballast)	118.8	151.9	167.6
Ballasting			
In closed areas			
Assembly central	0	0	0
Assembly off-set	LO R5	LO R8	LO R10
Assembly off-set with wall bracing	0	0	0
Outdoors			
Assembly central	0	0	0
Assembly off-set	LO R5	LO R8	LO R10
Assembly off-set with wall bracing	0	0	0

Please note: The ballasting table contains updated information. By releasing this document, the issue from 04.2019 loses its validity.



Item	Description	NUMBER USED FOR EACH TOWER MODEL			Weight approx. [kg]	Ref. No.
		1600102	1600103	1600104		
1	Ladder frame	6	8	10	4.7	1297.004
2	Double guardrail	4	6	7	5.9	1342.113 
3	Access deck	1	2	2	11.4	1242.113 
4	Telescoping stabiliser	4	4	4	5.2	1248.000 
5	Rotation lock for stabiliser	4	4	4	2.8	1248.261 
6	Toe board unit	1	1	1	5.6	1240.113 
7	Wheel	4	4	4	3.9	1300.150 
8	Spring clip	8	12	16	0.1	1250.000
9	SoloTower assembly hook (set of 4)	1	1	1	1.2	1300.002 
10	SoloTower assembly bag	1	1	1	0.2	1300.003 

 available ex plant warehouse

Subject to technical modification. Component weights are subject to fluctuations due to tolerances and may therefore diverge from what is specified. Deliveries shall be made exclusively in accordance with our currently valid General Terms of Sale.