

OPERATING MANUAL

Pile Chamber Series 400



WESTPORT
EQUIPMENT

manufacturer:

SBH Tiefbautechnik GmbH

Ferdinand-Porsche-Str. 8

D – 52525 HEINSBERG

phone:

+49 24 52 / 91 04 0

fax:

+49 24 52 / 91 04 50

e-mail:

info@sbh-tiefbautechnik.com

homepage:

http:\\ www.sbh-tiefbautechnik.com

Contents

General instructions

Lifting & transporting	3
Measures to reduce danger	3
Maintenance & repair	3

System drawing pile chamber with spindles	4
--	---

Technical parameters	5
-----------------------------	---

Pile Chamber inner plate t = 120mm	5
Pile Chamber inner plate t = 170mm	5
Spindles	6
Accessories	

Assembly instructions	7
------------------------------	---

Installation instructions	8
----------------------------------	---

In general	8
Allowed tensile forces	8
Installation of initial pile chamber unit	8
Placing of trench sheets KD6/8	8
Installation of walers on site	9
Installation of further pile chamber units	9

Re-Installation	10
------------------------	----

System drawing pile chamber with rolling strut shoring & walers	11
--	----

System drawing with rolling strut shoring and shoring plates	12
---	----

Technical parameter	13
----------------------------	----

pile chamber inner plate t = 120mm	13
pile chamber inner plate t = 170mm	13
In general	13

Installation instructions	4
----------------------------------	---

Pile chamber with RS shoring & walers	14
Putting in of trench sheets KD6/8	15
Installation of walers	16
Pile chamber with RS shoring & slide rail plates	16

Re-installation	16
------------------------	----

General instructions

The shoring must be without gap and close to the ground. The limiting values for the max. loads have to be kept strictly. Single shoring sections (boxes) may only be used if the front and rear faces are properly secured.

The following rules and regulations have to be followed in their valid version:

- Regulations of the BG-Fachausschuss Tiefbau (technical committee civil and underground engineering)
- DIN 4124 Baugruben und Gräben (excavation pits and trenches)
- DIN EN 13331 Teil 1 & 2 Grabenverbaugeräte (part 1 & 2 construction equipment)
- Regeln für Sicherheit und Gesundheit bei der Arbeit (rules for safety and health during work)
- Unfallverhütungsvorschriften / Arbeitsschutzvorschriften (accident prevention and safety at work rules)

Our shoring components have the GS-Sign „Certified Safety“.

During installation the instructions of this operating manual have to be followed.

Lifting & Transporting

- The shoring may only be attached at the corresponding eyes and openings and/or lifting accessories.
- The lifting accessories must be adapted to the weight which must be transported.
- For safety reasons only load hooks with hook safety must be used.
- The allowed tensile forces have to be kept in any case.
- The transporting has to be carried out next to the soil and unneeded pendulum movements have to be avoided.
- It is forbidden to enter the swivel range of the lifting tool and to stay under floating loads.
- It has to be paid attention to overhead contact lines.
- Engine driver and instructor must have face-to-face interaction.

Measures to reduce danger

- The construction site has to be sufficiently secured and marked.
- Neighbouring traffic flow has to be made possible by means of security personnel if needed.
- The personnel must wear protective clothing (helmet / safety shoes / gloves).
- Possible instabilities as a result of wind loads, during the assembly and installation, must be considered.
- The shoring components must be layed down – preferably in horizontal way – on a firm underground.
- In case of slopes it has to focus on a stable storage or mounting of pre-assembled components.

Maintenance & repair

- As a matter of principle, the operability of all shoring components must be checked before use.
- Defective or deformed components may not be used in any case.
- Slighter damages may be repaired by yourselves after consulting SBH. Otherwise, our service at SBH is at your disposal if desired.
- Only original spare parts of SBH may be used.
- According to intenseness of use, the components should be painted with anti-corrosive paint every 2 years.

System drawing Pile Chamber with spindles

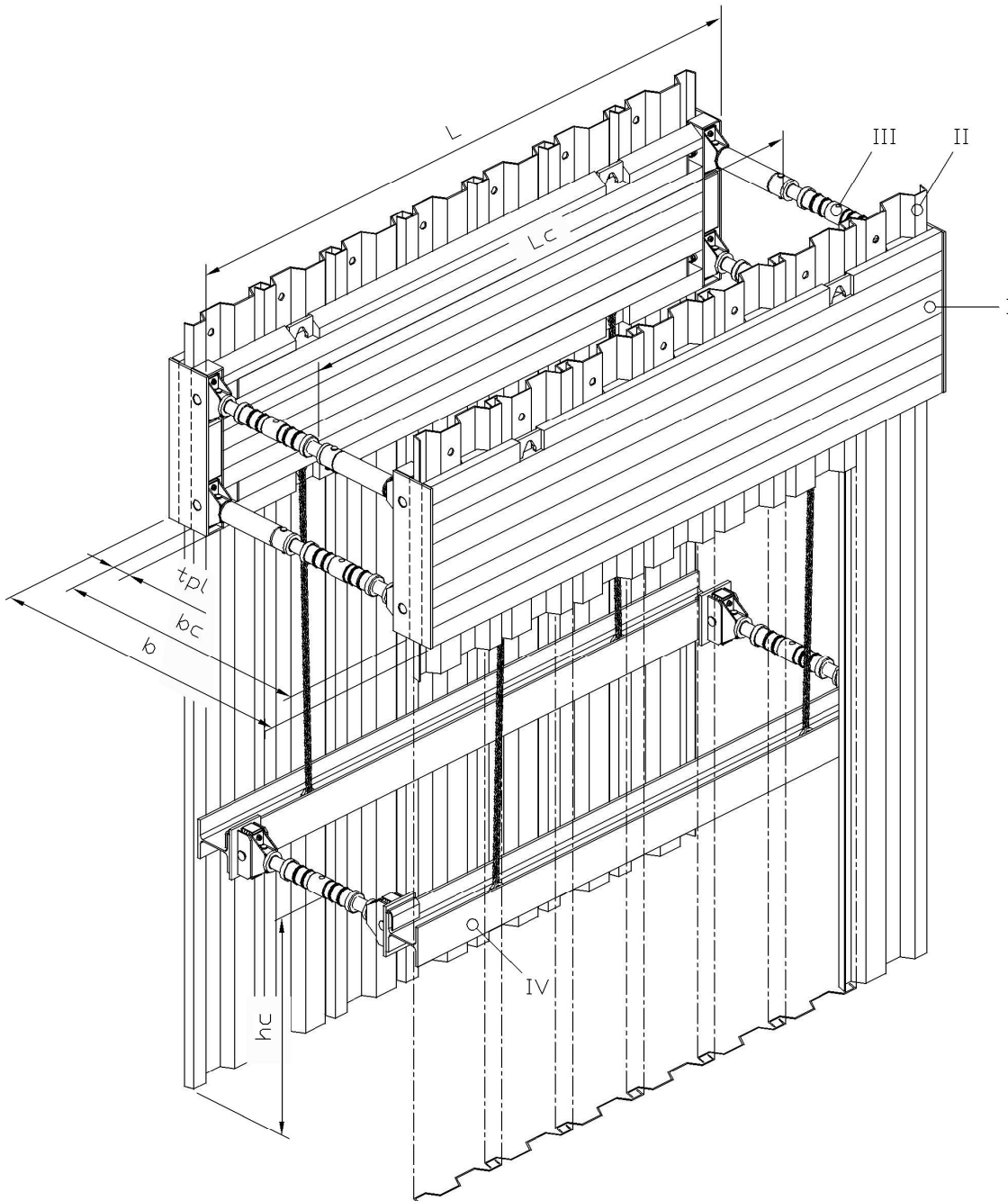

I pile chamber box
 II trench sheet KD6/8
 III spindles
 IV waler

b trench width
 bc working width
 tpi linner plate thickness

hc spindle clearance height
 L plate length
 Lc pipe clearance length

TECHNICAL DATA SHEET

Slide Rail Pile Chamber



Technical Parameter

inner plate thickness = 120 mm

allowed plate moment = 111,1 kNm
 allow. side profile moment = 6,75 kNm
 plate height = 1,00 m

plate length		clearance length	allowed boom bracing load	weight per plate
LDKE [m]	L with guide [m]	Lc in pile chamber [m]	q [kN/m]	without/with guide [kg]
1,90	2,00	1,62	261,2	470 / 505
2,34	2,44	2,06	171,6	560 / 595
2,84	2,94	2,56	116,6	660 / 695
3,42	3,52	3,14	80,4	775 / 810
3,92	4,02	3,64	61,2	875 / 910

pile chamber inner plate reinforced = 170 mm

allowd plate moment = 279,1 kNm
 allow. side profile moment = 6,75 kNm
 plate height = 1,00 m

plate length		clearance length	allowed boom bracing load	weight per plate
LDKE [m]	L with guide [m]	Lc in pile chamber [m]	q [kN/m]	without/with guide [kg]
4,42	4,52	4,14	116,8	1325 / 1360
4,92	5,02	4,64	94,3	1470 / 1505
5,42	5,52	5,14	77,7	1605 / 1640
5,92	6,02	5,64	65,2	1750 / 1785
6,42	6,52	6,14	55,4	1995 / 2030
6,92	7,02	6,64	47,7	2140 / 2175

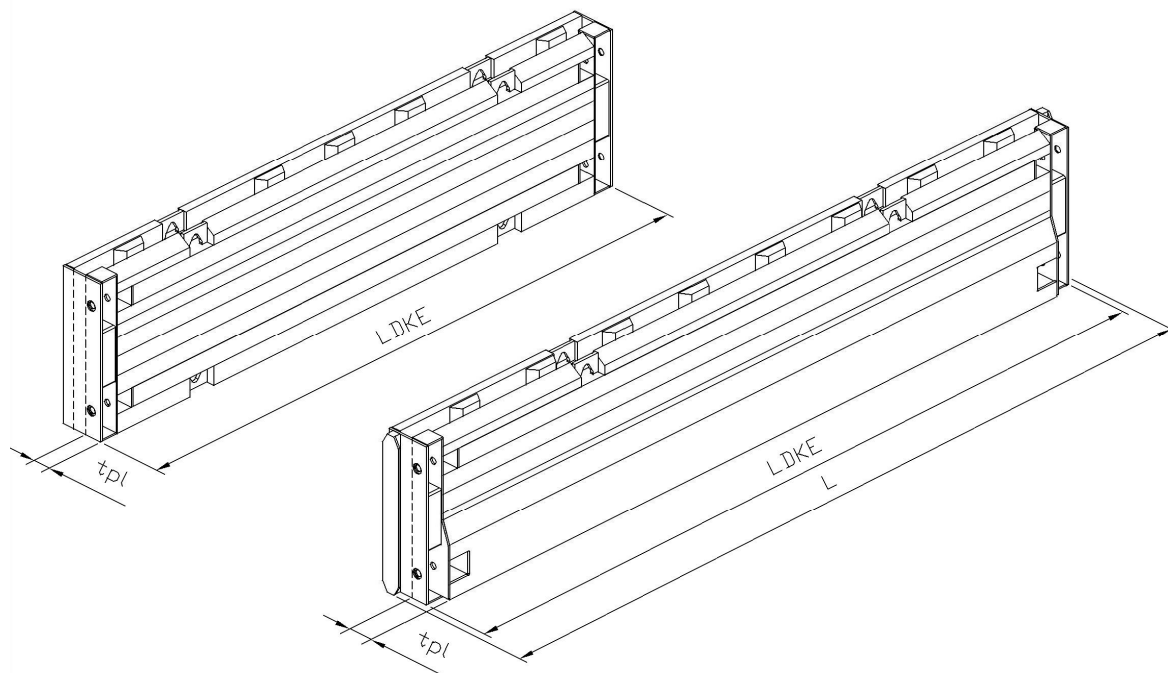

TECHNICAL DATA SHEET

Slide Rail Pile Chamber



Spindles type 031/185 blue

allowed moment = 1,7 kNm
allowed tensile force = 218 kN

number of extension pipes a 0,50 m	working width b_c between			trench width [m]	allowed compressive force [kN]	weight total [kg]
	sheets [m]	inner plates [m]	inner plates reinf. [m]			
0	1,00 – 1,28	0,76 – 1,04	0,66 – 0,94	1,30 – 1,58	468	65,0
1	1,50 – 1,78	1,26 – 1,54	1,16 – 1,44	1,80 – 2,08	403	84,8
2	2,00 – 2,28	1,76 – 2,04	1,66 – 1,94	2,30 – 2,58	348	104,6
3	2,50 – 2,78	2,26 – 2,54	2,16 – 2,44	2,80 – 3,08	299	124,4
4	3,00 – 3,28	2,76 – 3,04	2,66 – 2,94	3,30 – 3,58	254	144,2
5	3,50 – 3,78	3,26 – 3,54	3,16 – 3,44	3,80 – 4,08	210	164,0
6	4,00 – 4,28	3,76 – 4,04	3,66 – 3,94	4,30 – 4,58	165	183,8

Accessories

no.	description	use for	dimensions [mm]	weight [kg]
1	spring spindle holder	spindle	95/290 * 193	13,1
2	spindle	plates		40,2
3	pin with clip 4,5	extension pipe	ø20 * 147	0,4
4	pin with clip 6,3	spring spindle holder & connector	ø40 * 160	1,7
5	extension pipe	spindle	ø121 * 500 ø121 * L	19,8
6	spring spindle holder socket for HEB 240	waler by customers	220 * 310	17,0
	spring spindle holder socket for HEM 240	waler by customers	220 * 280	16,2

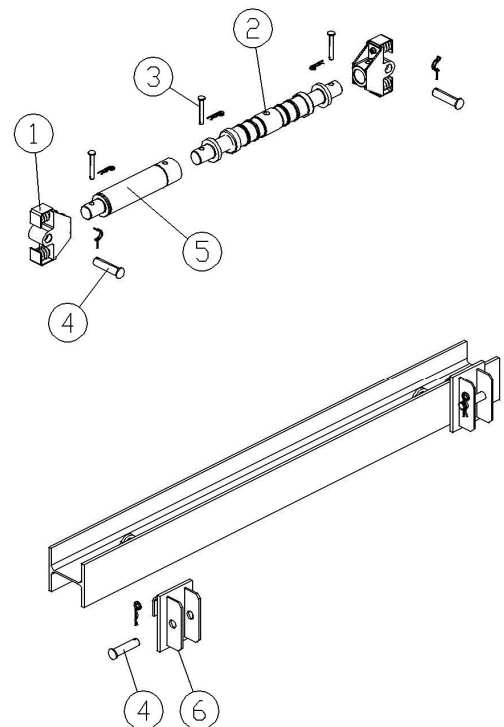

Assembly instructions

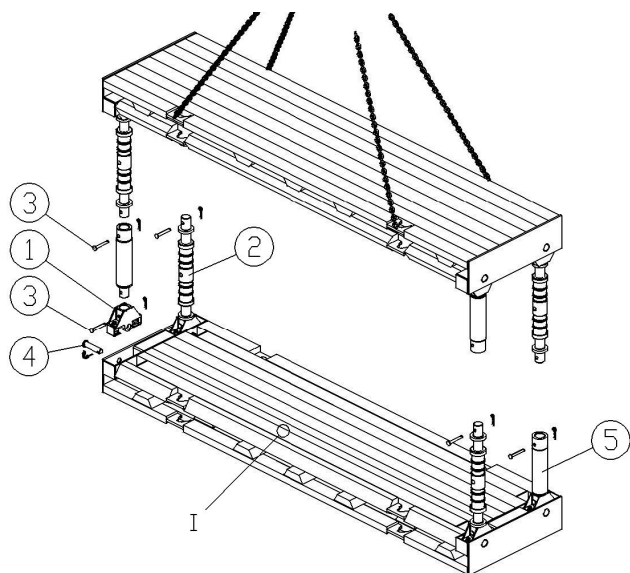

- | | | | | | |
|---|-------|---|-----------------------|---|-------------|
| I | plate | 1 | spring spindle holder | 4 | pin Ø40*160 |
| | | 2 | spindle | 5 | extension |
| | | 3 | pin Ø20*147 | | |

Put the pile chamber plate with the spindle sockets to the top onto a flat and firm underground.

Afterwards put the spring spindle holders into the spindle sockets, fix with the pins Ø40*160mm and secure by means of the clips.

For trench widths up to 2,00m the spindles and extension pipes are offset mounted to the spring spindle holders at one pile chamber plate, for larger trench widths at the two pile chamber plates. Then fixed with the pins Ø20*147mm and secured by means of the clips.

The extension up to the required trench width is effected by means of extensions pipes as described before.

After mounting all spindles, one pile chamber plate is put into the corresponding lifting/transportation eyes at the top and the bottom of the plate and put from the top onto the spindles of the plate below, pinned and secured.

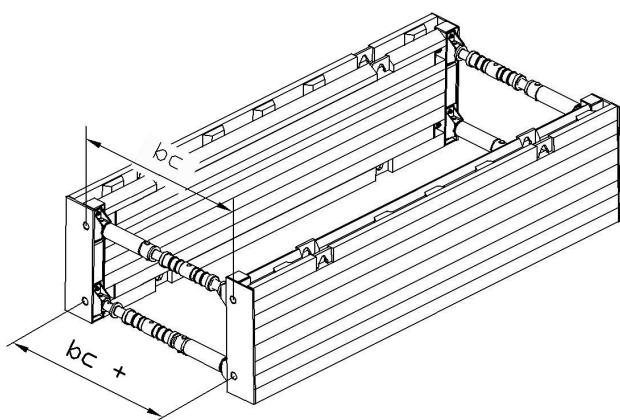

The spindles are now extended/spindled out up to the required trench width (fine adjusting).

Attention has to be paid that the bottom spindles have to be spindled out more than the upper ones in order to achieve an A-arrangement of the plates.

The shoring width above must be lower than below.

Installation instructions

In general

The usage of pile chambers is best for crossing supply lines. This system combines shoring plates with trench sheets. The pile chamber thereby provides the guiding frame for the trench sheets and at the same time is the upper waler.

Standardly our pile chambers are used with trench sheets type KD6/8.

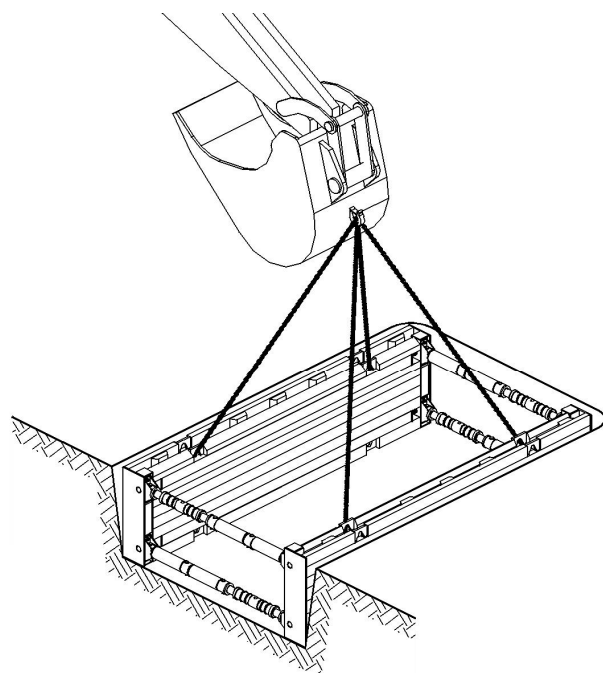

allowed tensile forces

At the single attachment points the following tensile forces can be beared:

per lifting eye	= 153 kN
per FI 30*40 in waler area	= 66 kN
per eye in waler by customers	= 49 kN

Installation of the first pile chamber unit

Pre-excavation of max. 1,00 m and not more than one pile chamber length. In principle the pre-excavation complies with the type of soil and safety regulations.

Attach the chains to the four eyes at the top of the inner plate and place the pile chamber box which is already spindled out to the required trench depth into the pre-excavated trench and align.

Spindle out the pile chamber against the trench walls. The excavation or hole between pile chamber and soil has to be filled and compacted!

The excavator preferably works ahead of the trench.

Placement of trench sheets KD6/8

Place the trench sheets into the guides between inner and outer plate and press in by the excavator bucket. By means of the welded guides, the trench sheets are properly guided and kept.

The lowering of the trench sheets is effected in turns with the excavation.

The trench sheets have to be pressed in by the excavator bucket or by vibration and not by battering. Barriers e.g. fragments of walls or boulders must be removed by hand.

Excavate about further 0,50m and press in the trench sheets by turns.

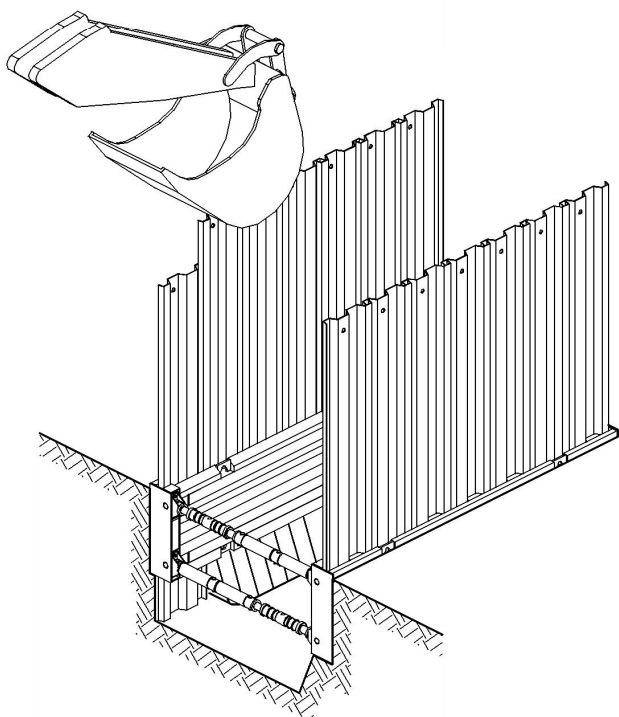

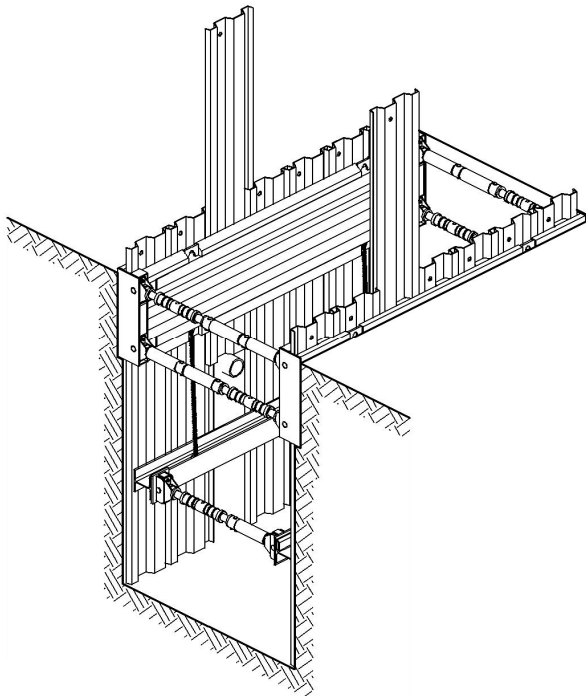

Repeat this procedure until reaching the required trench depth.

When having crossins, the installation of the trench sheet concerned is effected up to the summit of the crossing. These trench sheets have to be locked against further sliding. Underneath the crossing it has to be shored conventionally e.g. with timber.

Installation of walers on site

Up to a trench depth of ~3,00 m it can be shored without walers on site. For deeper trenches and/or with buildings at risk of settlements, walers on site have to be provided. These have to be chosen according to static requirements and have to be checked upon every case of operation!

The site specific engineering reports position and rating of the required waler.

The walers are aligned underneath the pile chamber, fixed to the pile chamber by means of chains and kept at bay by SBH spring spindle holder sockets and SBH spindles.

Installation of further pile chambers

Once the foregoing shoring section is installed to full depth, the installation of the next pile chamber can be started.

The installation is effected as described before.

After the installation of the pile chamber boxes, the pipe laying can be started in the shored and secured trench.

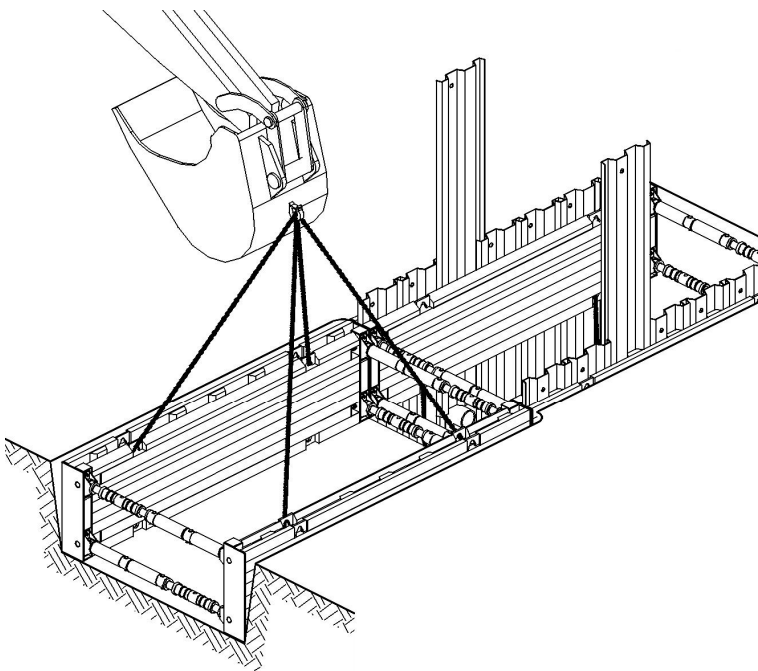

Re-Installation

After completion of the pipe laying the re-installation of the trench sheets is effected.

According to compacting possibilities bring in about 0,50 m filling material. Lift the trench sheets by the filled height. That followed the compaction of the filling material.

Repeat this procedure as described before until the walers and finally the trench sheets can be lifted out of the trench according to the safety regulations. Finally the pile chamber is lifted out of the trench.

Use the appropriate eyes at the inner plates to lift the pile chamber only. It is not allowed to lift at the extension pipes!

We strongly advise that it is forbidden to enter the danger zone during the installation and re-installation.

Attach lifting accessories at least at 2 eyes of the particular pile chamber plate.

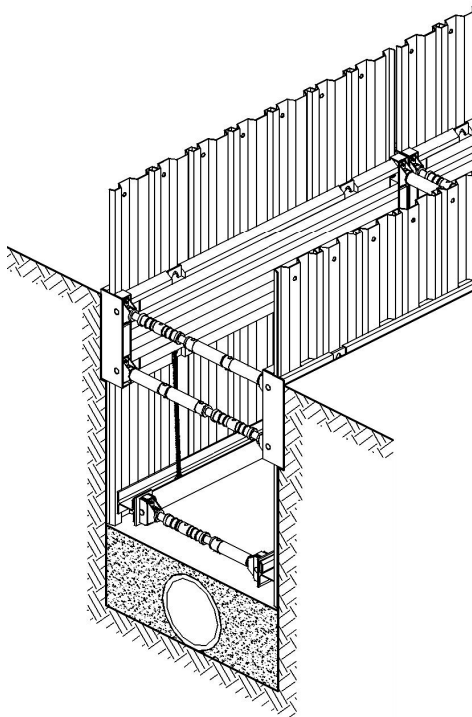
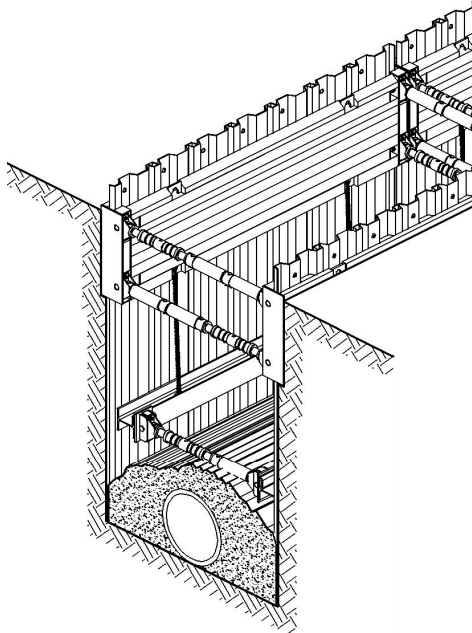

System drawing pile chamber with rolling strut shoring and waler

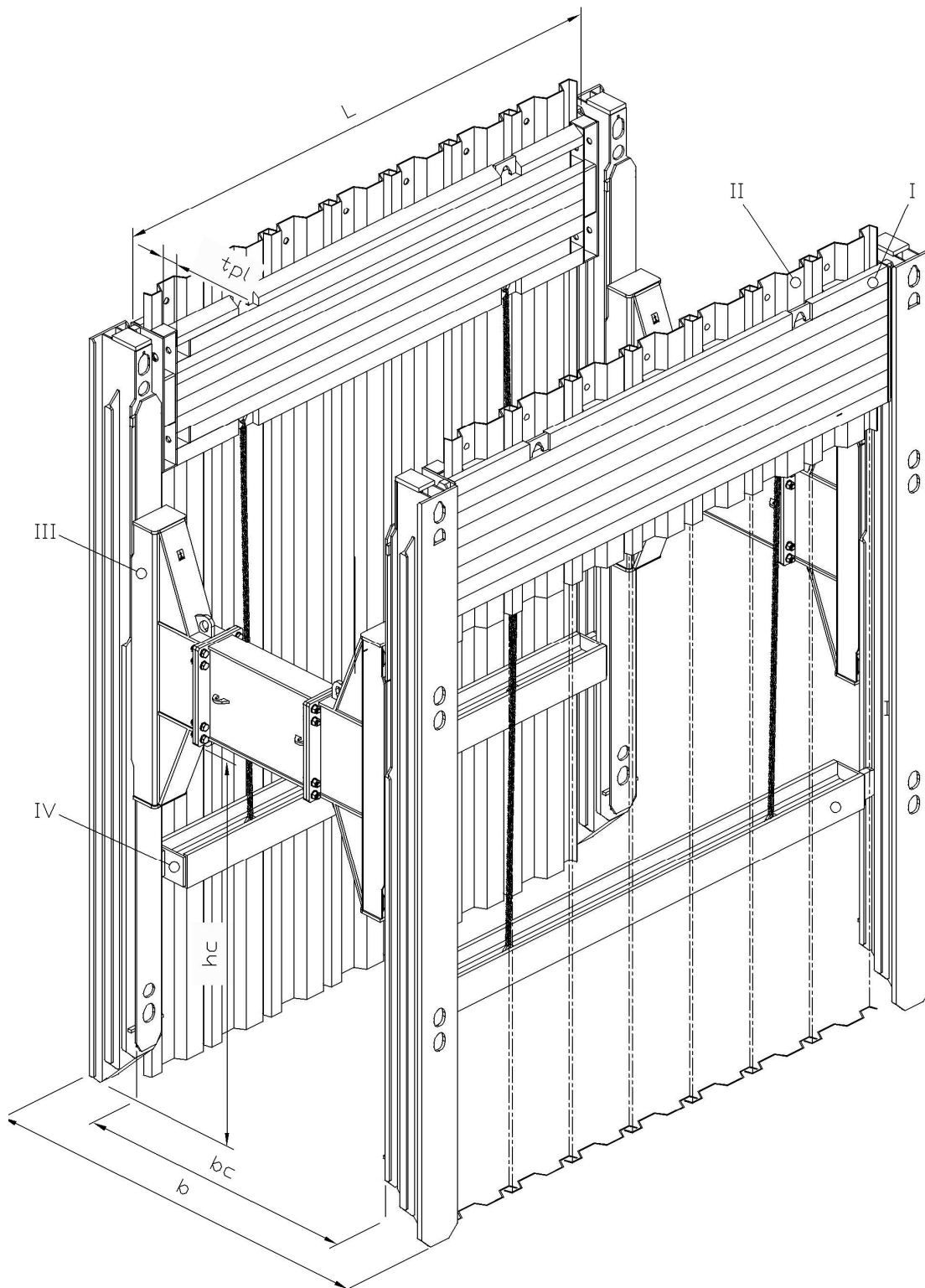

- | | | | | | |
|-----|---------------------|-----|--------------------------|---|--------------|
| I | pile chamber | b | trench width | L | plate length |
| II | trench sheets KD6/8 | bc | working width | | |
| III | RS-shoring | hc | spindle clearance height | | |
| IV | waler | tpi | linner plate thickness | | |

System drawing pile chamber with rolling strut shoring and shoring plates

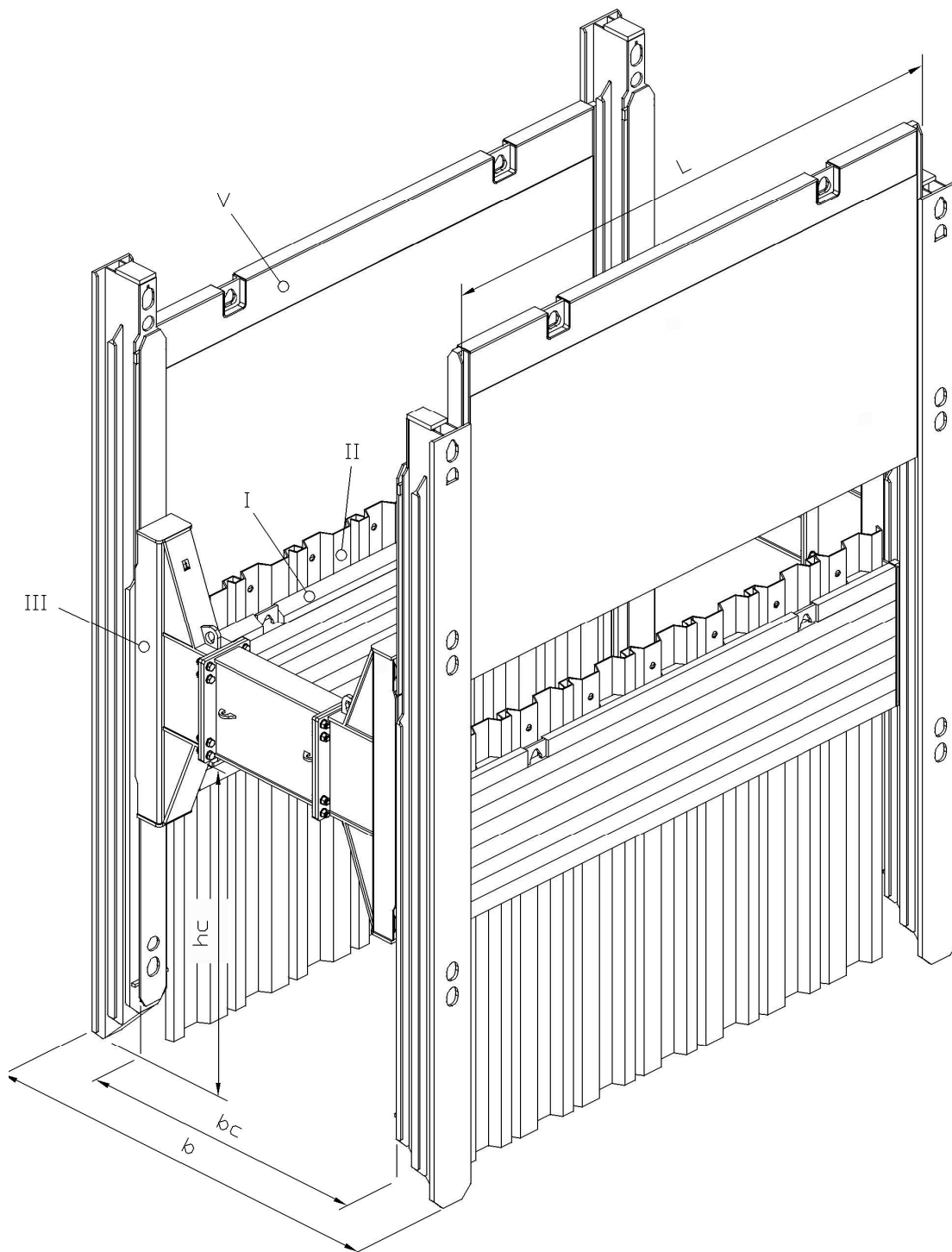

- | | | | |
|-----|---------------------|----|--------------------------|
| I | pile chamber | b | trench width |
| II | trench sheets KD6/8 | bc | working width |
| III | RS-shoring | hc | spindle clearance height |
| V | shoring plate | L | plate length |

TECHNICAL DATA SHEET

Slide Rail Pile Chamber



Technical parameter

inner plate thickness = 120 mm

allowed plate moment = 111,1 kNm
 allow. side profile moment = 6,75 kNm
 plate height = 1,00 m

plate length L with guide [m]	clearance length L _c in RS [m]	allow. boom bracing load q _{DKE} [kN/m]	weight pile chamber plate [kg]	waler type	allowed boom bracing load q _{Gurt} [kN/m]	weight waler [kg]
2,00	1,82	261,2	505	HEB 240	339,5	190
2,44	2,26	171,6	595	HEB 240	223,0	230
2,94	2,76	116,6	695	HEB 240	151,5	270
3,52	3,34	80,4	810	HEM 240	210,1	570
4,02	3,84	61,2	910	HEM 240	160,0	650

inner plate thickness reinforced = 170 mm

allow. plate moment = 279,1 kNm
 allow. side profile moment = 6,75 kNm
 plate height = 1,00 m

plate length L with guide [m]	clearance length L _c in RS [m]	allow. boom bracing load q _{DKE} [kN/m]	weight pile chamber plate [kg]	waler type	allowed boom bracing load q _{Gurt} [kN/m]	weight waler [kg]
4,52	4,34	116,8	1360	HEM 240	125,9	730
5,02	4,84	94,3	1505	HEM 240	101,6	810
5,52	5,34	77,7	1640	HEM 240	83,7	890
6,02	5,84	65,2	1785	HEM 300	135,2	1445
6,52	6,34	55,4	2030	HEM 300	115,0	1570
7,02	6,84	47,7	2175	HEM 300	99,0	1680

In general

Pile chamber plates with lateral guide are also used with the Rolling Strut shoring. There are two possibilities for the use of pile chamber plates in the area of crossings.

1. Pile Chamber with Rolling Strut Shoring and waler

The pile chamber plate is placed in the outer guide of the slide rail, flush with the top ground surface. According to static requirements, one or several walers are positioned beneath in the inner guide of the slide rails.

2. Pile Chamber with Rolling Strut Shoring and shoring plates

The installation of the pile chamber plate is effected in combination with shoring plates, whereat the shoring plates are placed in the outer guides and the pile chamber plates beneath in the inner guides of the slide rails.

Installation instructions

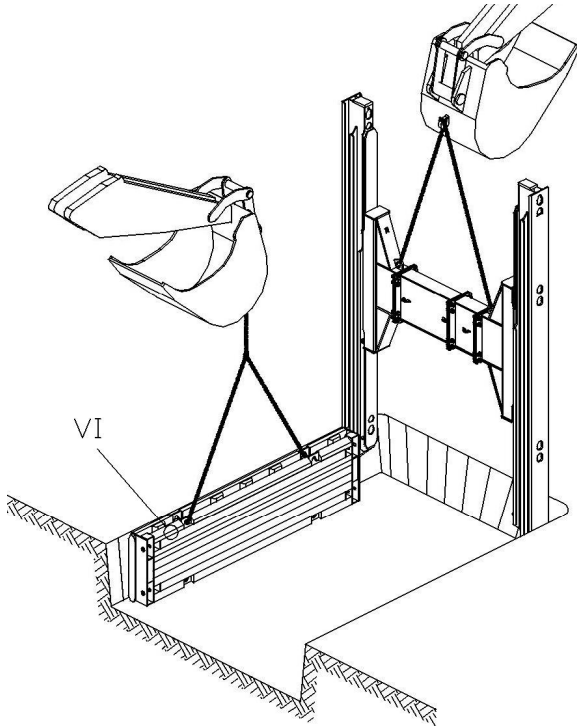

If the pile chamber plates are used with the RS shoring no further assembling at the pile chamber plates is needed. The pile chamber plates with lateral guides are used like shoring plates. We here do not go into the assembly of the Rolling Strut shoring (please see operating manual RS Double Slide Rail, Series 750).

Pile Chamber with RS-shoring & waler

Pre-excavation max. 1,00 m and not more than one shoring section length. In principle the pre-excavation complies with the type of soil and the safety regulation.

Place the pile chamber plate in the pre-excavated trench, push in and hold/supported by means of the boom of the 1. excavator. Hook in the pre-assembled slide rail frame at the 2. excavator, which must have an appropriate height of stroke, swing over the pile chamber plate into the pre-excavated trench, mount into the outer slide rail guide and push in.

In this phase the trench may not be entered.

Mount the second pile chamber plate into the outer guide of the slide rail and slide down to the trench sole.

Align the two pile chamber plates by means of spacers / assembly help parallel and rectangular over the diagonal.

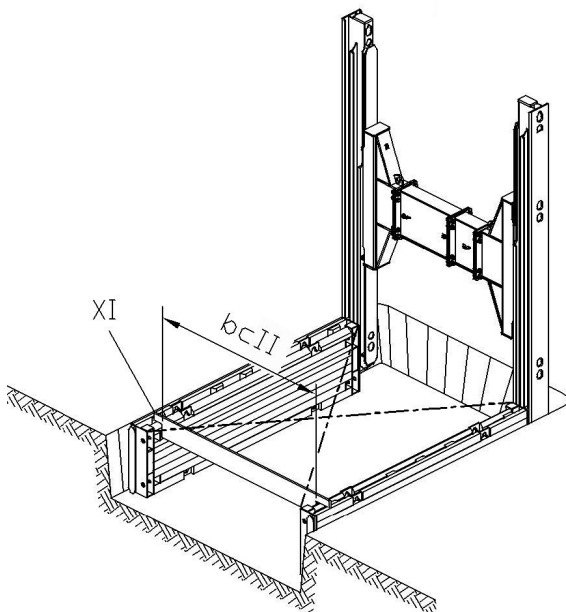

- VI DK-Platte
- XI Aufbauhilfe
- bcII Plattenabstand

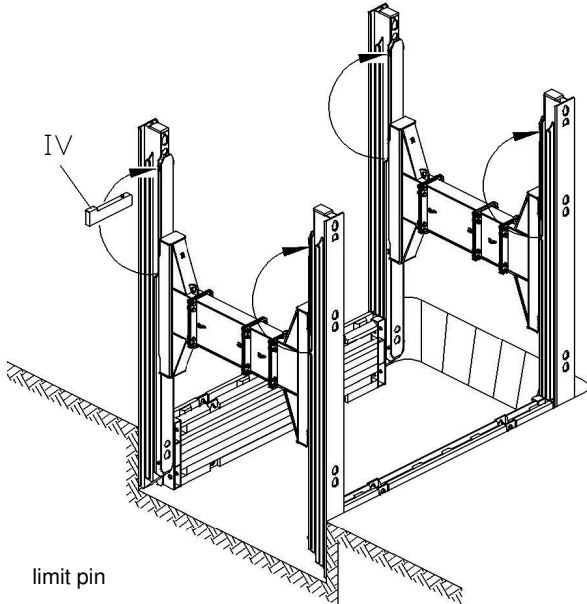

IV limit pin

Now the second pre-assembled slide rail frame is directed over the two plate guide profiles and pushed into the soil. Re-push the slide rails and if necessary align. Fill the excavation / hole between shoring and soil and compact!

The upper limit pins now have to be repositioned, as described. Now the rolling strut pair can slide on the rails and allows the method of operation of the rolling strut shoring. By positioning of the limit pin in the upper hole, an unintentional slipping of the rolling strut is avoided.

Placement of the trench sheets KD6/8

Place the trench sheets into the guides between inner and outer plate and press in by the excavator bucket. By means of the welded guides, the trench sheets are properly guided and kept.

Excavate about further 50 cm and press in rails, rolling struts and trench sheets by turns. Please pay attention that all components are pressed or pushed in about the same lift and that the rolling strut is positioned most centrally in the slide rail frame.

The single shoring components have to be pressed in by the excavator bucket and not by battering. Barriers e.g. fragments of walls or boulders must be removed by hand.

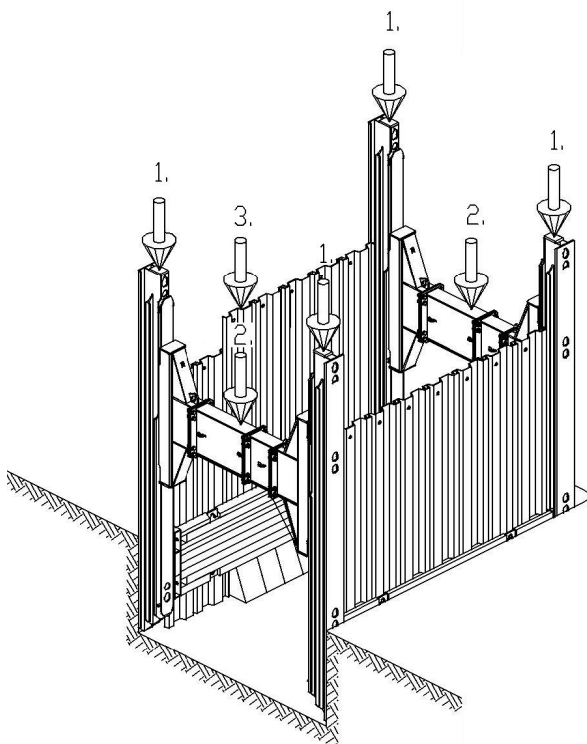

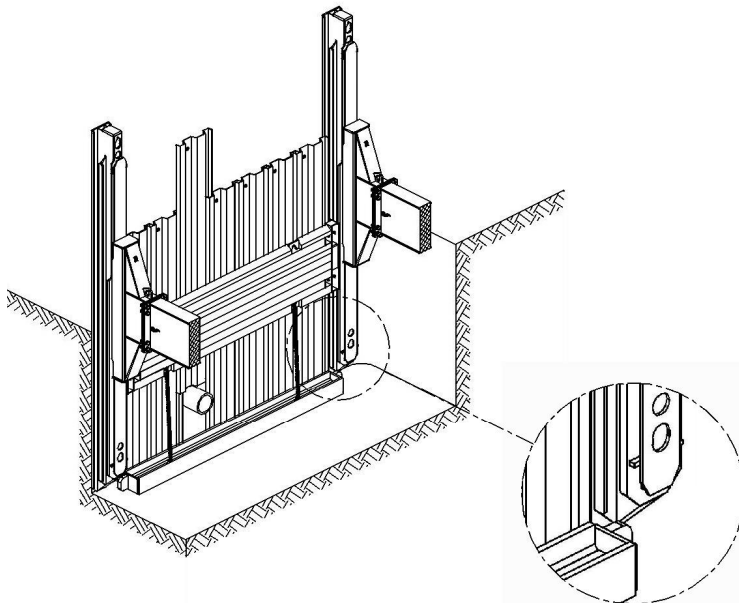

Installation of the waler

As soon as practicable the waler has to be installed in the inner guide of the slide rail, underneath the crossing.

Thereby, the waler is placed and aligned in excavation depth, directly in front of the trench sheets, underneath the slide rail. The guides at the waler must be underneath of the inner guide of the slide rail.

Carefully push in the slide rails and if necessary align the waler.

Afterwards fix the waler by means of chains to the pile chamber plates. According to statical requirements, provide further walers.

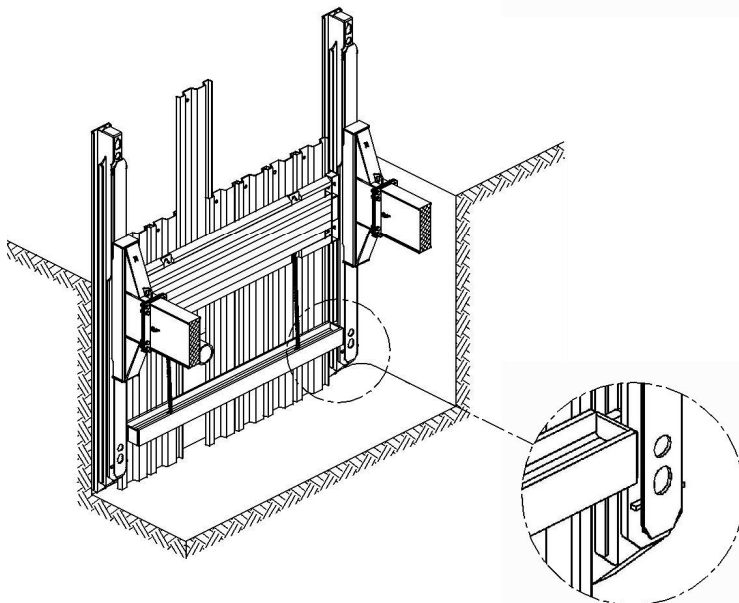

Pile Chamber with RS-Shoring and shoring plates

Is there a crossing in the lower area of the trench only, it can be shored above with shoring plates and below with pile chamber plates. In this case the installation is effected corresponding to the instructions described before, whereat the the pile chamber plates are placed in the inner guide of the slide rail.

Re-Installation

At the beginning of the re-installation remove the lower limit pins at the rolling strut.

According to compacting possibilities bring in max. 50cm filling material.

Lift the shoring components by the filled height. That followed the compaction of the filling material.

Repeat this procedure as described before until the shoring can be lifted out of the trench according to the safety regulations.

Use the appropriate eyes only to lift the shoring components.

We strongly advise that it is forbidden to enter the danger zone during the installation and re-installation.